

# Gravitational Wave Detection and Squeezed Light

David Sliski

November 16, 2009

## 1 Introduction

Among the revolutionary predictions of Einstein's theory of general relativity is the existence of gravitational waves, which are perturbations in the fabric of spacetime that travel at the speed of light. The first indirect evidence pointing to their existence came from the observation of the Hulse-Taylor pulsar in 1974[4]. More recently, gravitational wave observatories like the Laser Interferometer Gravitational-wave Observatory (LIGO) and Virgo have been built with the purpose of detecting gravitational waves (GW) directly, providing not only further evidence in support of general relativity, but also a whole new way of viewing the cosmos.

The strain produced by a passing gravitational wave (namely, the relative change in the length of the matter a gravitational wave passes through) is so small that the best sensitivity achieved by the detectors has not produced a positive detection as of today. With a clear understanding that there should be gravitational waves, scientists are working on improving the sensitivity of the detectors to increase the likelihood of a detection. One of the main sources of noise for the next generation gravitational wave detectors, such as advanced LIGO, is shot noise. Shot noise dominates the noise spectrum above a few hundred Hz. This noise is due to uncertainties in quantum statistics, according to the generalized uncertainty principle. There are two ways to reduce the shot noise. The first way is to increase the intensity of the

laser of the interferometer. Method one will increase the number of photons per second at the detector thus reducing the the shot noise by the square root of N, the number of photons. The second way to reduce the shot noise in a GW detector is to squeeze the light. One can “squeeze light” or reduce the uncertainty in the phase quadrature and increase the noise in the amplitude quadrature such that uncertainty principal is still satisfied.

Squeezing was first successfully demonstrated at Bell Labs in the 1980s. However, those experiments only dealt with high frequencies around a few MHz. For squeezing to be useful for gravitational wave detection it must be possible to squeeze light in the detection band, 10 Hz to tens of kHz. The group at the Australian National University (ANU) has developed a method to squeeze light into the audio band, hundreds of Hz. My summer project was to work with the group at ANU to improve the squeezer so that it could be tested at LIGO in the near future. The two major components of the project related to locking the squeezed beam and controlling air currents at the detector.

## 2 Theory

The shot noise limit is a consequence of the uncertainty principal, the generalized version of which is:

$$\sigma_A \sigma_B \geq \left| \frac{1}{2i} \langle [A, B] \rangle \right| \quad (1)$$

Here the two operators A and B correspond to two observables and sigma a and sigma b represent the uncertainty in the measurements of a and b. The quintessential example of the uncertainty principal is the electron cloud around an atomic nucleus; in this case, A and B are the position and momentum operators.

If we let the operators A and B represent the amplitude and phase quadrature of an electromagnetic field  $a_1$  and  $a_2$ , respectively, then the uncertainty principal yields

$$\sigma_{a_1} \sigma_{a_2} \geq 1 \quad (2)$$

When considering interferometric gravitational wave observatories, the most relevant of these uncertainties is the phase quadrature  $\sigma_{a_2}$ . If one can reduce the uncertainty in the phase quadrature then one can more precisely measure length contractions in the interferometer.

If one minimizes the noise in any laser the state of the light is said to be coherent. This means that the uncertainty principal is saturated. A squeezed state is defined as  $\sigma_{a_1}\sigma_{a_2} = 1$  and  $\sigma_{a_1} \neq \sigma_{a_2}$ . The ball on stick model is a visual representation, in which the ball represents the uncertainty in either quadrature and the stick represent the phase.

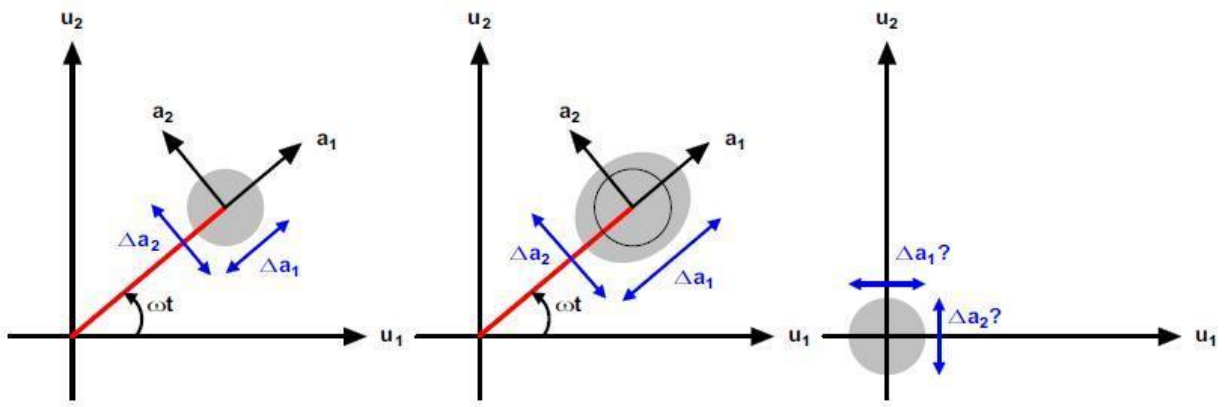

Figure 1: Left: A coherent state; defined as the minimum uncertainty or  $\sigma_{a_1}\sigma_{a_2}=1$ . Center: A noisy state both classically and quantum-mechanically compared with a coherent state. Right: A vacuum state that is similar to a coherent with no coherent amplitude. [1]

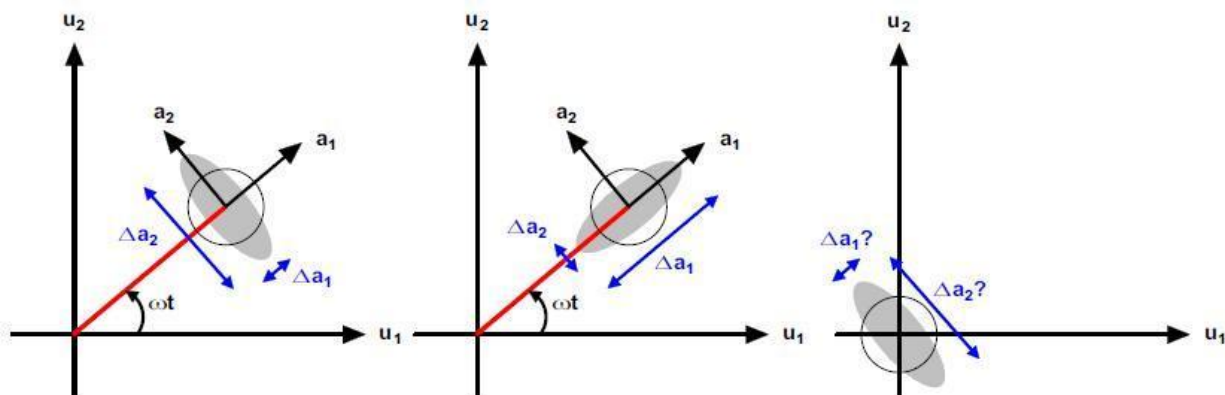

Figure 2: Left: An amplitude squeezed state compared with a coherent state. Center: A phase squeezed state compared with a coherent state. Right: A squeezed state of vacuum compared with a vacuum state. [1]

### 3 Implementation

Today, it is possible to squeeze light at high frequencies. However, squeezing light in the detection band of gravitational wave detectors has proved to be a great difficulty for scientists. For squeezed light to be useful for LIGO and other gravitational wave observatories one must be able to squeeze light in their detector band. One must also be able to control the squeezed state over measured time scales (hours). These are the main two problems facing squeezing light today for use in gravitational wave observatories.

#### 3.1 Previous experimental Setup

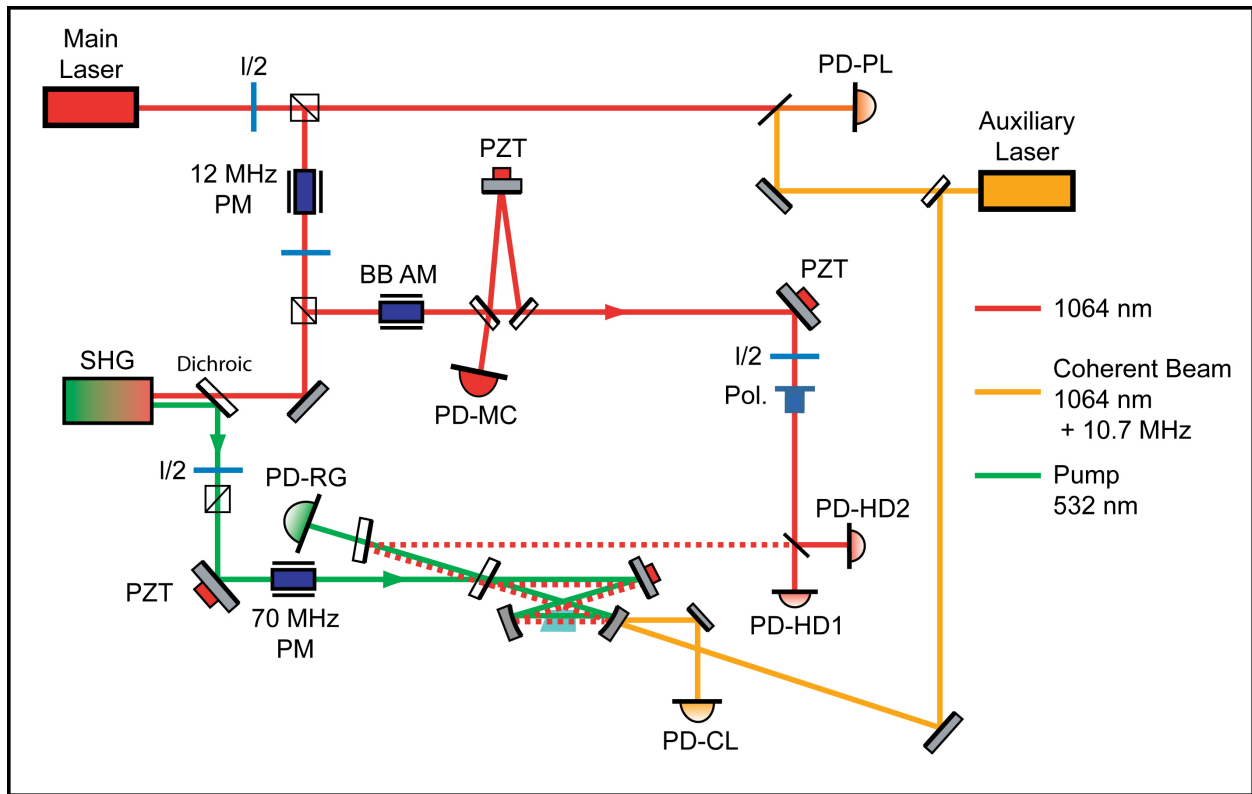

Figure 3: A simplified schematic of the optical layout as of June 2009 [2]

In figure three, the previous experimental setup is show. In this diagram the main laser outputs a beam which is split by a beam splitter. By controlling the polarization going into the beam splitter a small fraction of the light will be transmitted. A second, auxiliary laser

is added whose wavelength is the same as the main laser. This light is used to produce a beat between the two lasers, which allows the controller to lock the two lasers together. Following the main path of the laser, it passes through a 12 MHz phase modulator. By oscillating the light at a known frequency one can lock an optical cavity at resonance. Again the beam is split, with one half going to the Second Harmonic Generator (SHG), and the other half heading toward the homodyne detector. The laser's path to the homodyne detector runs through another modulator and triangular cavity. This cavity is a mode cleaner, which is to say any mode of the laser light that is not the one that is resonant in the cavity will be filtered out. Lastly the light is sent through a few wave plates that control the polarization going into the detector. Here at the homodyne detector the laser light is split 50-50 and detected with a pair of photodiodes. Following the path out of the second beam cube, the laser light passes into a linear cavity, specifically the SHG. Here the light passes through a crystal. Using the non linear properties of the crystal, two 1064 nm photons are combined to create one 532 nm photon, a photon with twice the initial energy. Again the light's polarization is controlled and the phase is modulated once again such that the optical parametric oscillator (OPO) has sidebands to lock the cavity on resonance. This cavity, which has four mirrors in a bow-tie configuration, requires a reference beam. This reference allows the user to monitor the phase of the light. If the phase of the light is known, then the angle of squeezing is known. The angle of squeezing refers to how much each uncertainty is squeezed, i.e. the angle between the semi-major axis of the squeezed ball and the amplitude axis. This squeezed beam is then injected into the signal port of the 50-50 beam splitter in the homodyne detector.

## 3.2 Novel Modifications

Conor Mow-Lowry, a graduate student at ANU and my adviser for the summer, suggested a modification to the locking scheme presented in Chelkowski's 2007 paper concerning coherent locking.[3] This modification called for injecting an auxiliary laser collinear with the main beam into the OPO. This would vastly improve the signal to noise ratio due to the high

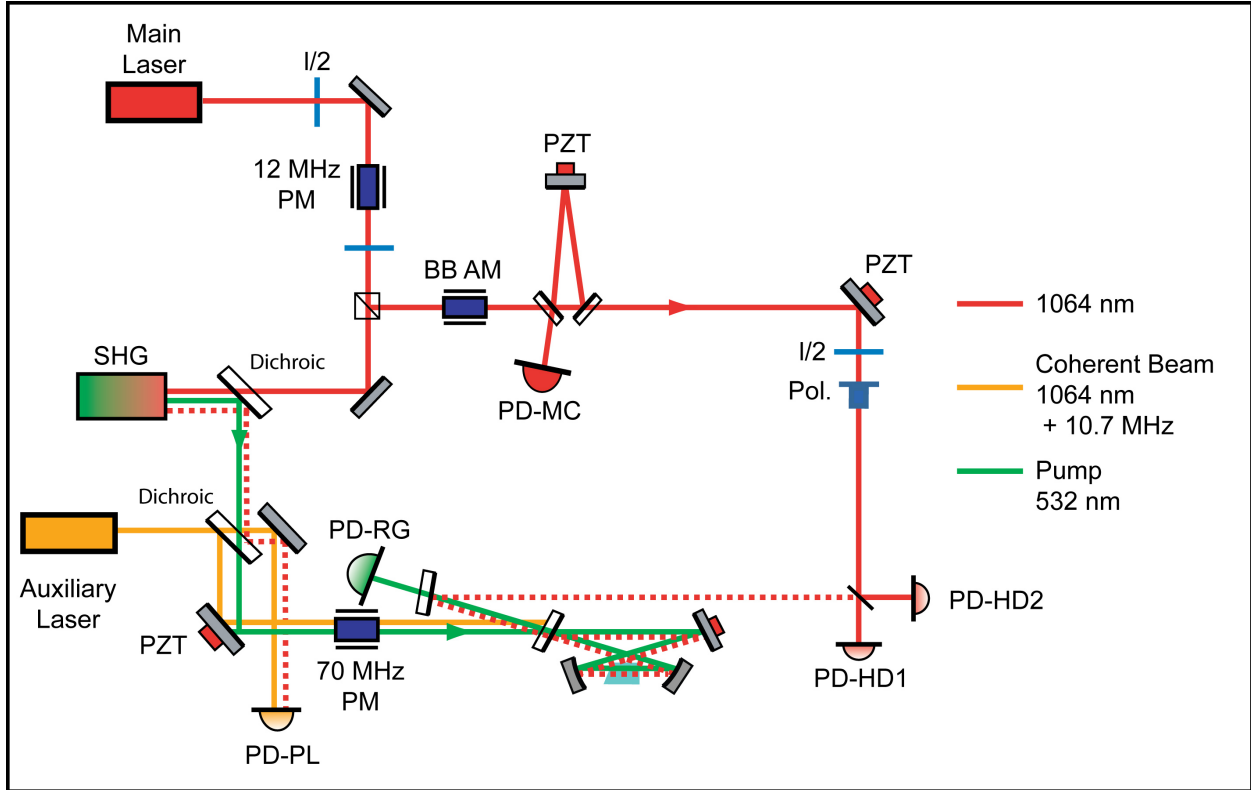

Figure 4: A simplified schematic of the optical layout as of August 2009

transmissivity of the mirror at the injection point. By removing many elements of the set up, mirrors, lenses, and path length, this method reduce the error found in the signal. However, to do this one still need a beat between the main laser and the auxiliary laser. To do this one has to use a dichroic, a mirror that reflect one wavelength and transmits another, to split the residual red light from the SHG from the green. At this point one can inject the auxiliary laser light at that dichroic. Since the dichroic is not perfectly reflective at 1064 nm some part of the beam will pass through. That light along with the red leakage beam from the SHG can be beat together and monitored at a photodetector.

To move the input of the auxiliary laser, an optical fiber was placed in the old beam path and output was placed on the other side of the table. Here the size of the beam, or waist, was measured. Comparing the output waist of the beam to the input waist to the OPO, I set up a series of lenses that mode matched the auxiliary laser to the main laser's path. With both beams having equal size and being collinear, I needed to set up a way to

monitor the beat between the two lasers. Here we used the leakage from the SHG and the transmitted field from the dichroic at the injection point. Because no process is perfectly efficient, a small amount of red light is emitted from the SHG. This light is reflected at the injection point. This dichroic is green transmissive and red reflecting. Additionally, not all of the red light from the auxiliary laser is reflected. The transmitted field from this laser is beat together with the leakage IR field from the SHG and is measured by a photodetector. This measurement, while small, allows us to lock the phase of the two lasers. Graphically the change can be seen in the figure four.

## 4 Results

Once the beam from the auxiliary laser was passed through a optical fiber the waist was measured. Classically one might consider a beam size to be infinitely small, while in this experiment the size of the beam must be controlled. The size of the beam is referred to as the waist. With the waist at the output of the fiber known and the waist going into the OPO known, a series of lenses was put in place to match the output to the desired input. With a correct beam size, a photodetector to monitor the beat between the two lasers, with the two beams collinear into the OPO, one could test this method for controlling the locking of the squeezed beam. Unfortunately, once everything was ready, the crystal inside the SHG appeared to be damaged. The resulting beam was not circular, in fact it rather resembled an off axis oval. I had to depart for the United States before any results were obtained. However, on August 24th, the ANU team was able to lock the OPO and get a result. Figure five represents a Fourier transform of the efficiency of the squeezer upon arrival at ANU in June of 2009. Figure six plots the measured squeezing as a function of time. Here we can see the difference between the squeezed beam vs a coherent beam as a function of time, with the blue line representing a normalized coherent beam and the black and pink lines representing locked squeezing and locked anti squeezing. One can compare these measured

values to the predicted uncertainties presented in figure 2. While the results were taken at a high frequency (100 KHz) the new method showed signs of progress in that the optical table stayed locked for more than 15 minutes. At the conclusion of this result the optical table was disassembled. With the new goal, of simplifying the set up and cleaning the different parts of the experiment so as to improve the results, the ANU team has embarked on a mission to squeeze light 6 dB below the shot noise limit in the frequencies most sensitive to gravitational wave detection.

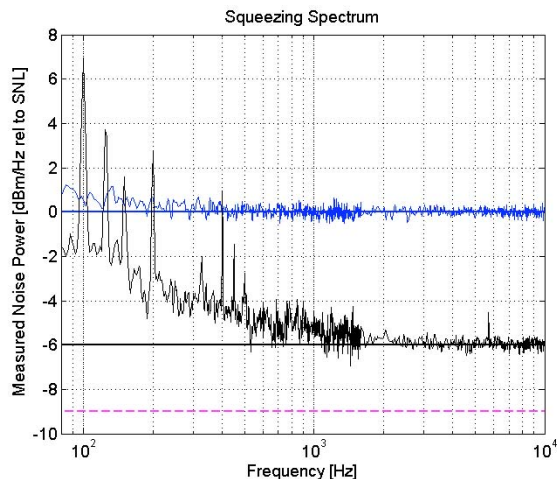

Figure 5: The top line represents the shot noise limit for the measurement, while the bottom line shows the amount of squeezing at a particular frequency. (June 2009)

## 5 Homodyne detector in Vacuum

Among the many updates to the squeezer table over the past few years was a metal box that covered the homodyne detector. This box has two holes in it, one for the coherent laser light to pass through and a second for the squeezed light to enter in. The box, which decreased the air currents around the beam splitter and the detector, as well as ambient light at the detector, caused a notable decrease in the noise while measuring squeezing. Given that a box decreased the noise, one might wonder what the effect of putting the detector in vacuum or in a sealed chamber would be. Pages ten, eleven, and twelve detail flanges that were



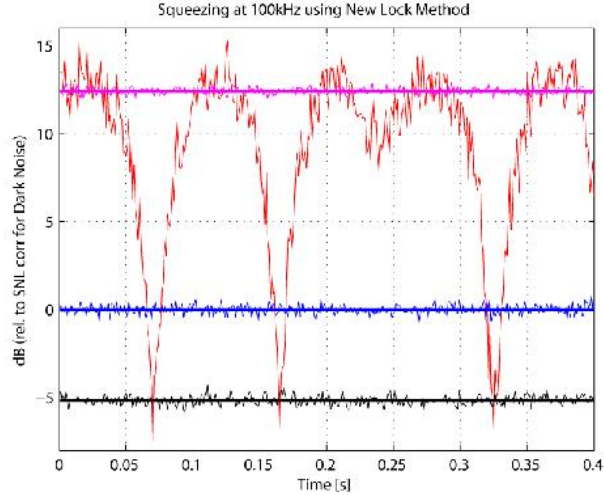

Figure 6: A time vs. SNL plot. The pink line is the measured uncertainty in the amplitude, blue as the shot noise limit, and black as the limit in the measured uncertainty in the phase

designed for a vacuum chamber to put the homodyne detector in. Pages ten and eleven are the drawings for a window flange, a three inch dual coated 1064 nm laser window is fit in between the two flanges. Once the two components are fit together, it will be attached to the chamber such that the vacuum is kept intact and the laser light is allowed to pass through. Page twelve details a second type of flange created for the chamber. This flange allows BNC cables to pass through the vacuum. This allows the components to be powered and to pass signals from the inside to the outside.

## 6 Acknowledgments

This project would not have been possible without the dedication that the National Science Foundation shows to young scientists. The University of Florida set up numerous opportunities for undergraduates to travel the world and learn from some of the best scientists on the planet. David McClelland for accepting me into his institution and allowing me to work hands on with some of the most cutting edge equipment in the field. Conor Mow-Lowry for spending hours not only mentoring me, teaching me, guiding me and motivating me to become a better scientist. Sheon Chua and Michael Stefszky who provided excellent addi-

tional support understanding the material and mentoring me in the lab. The rest of the ANU physics department for making my stay in their country a most memorable summer.

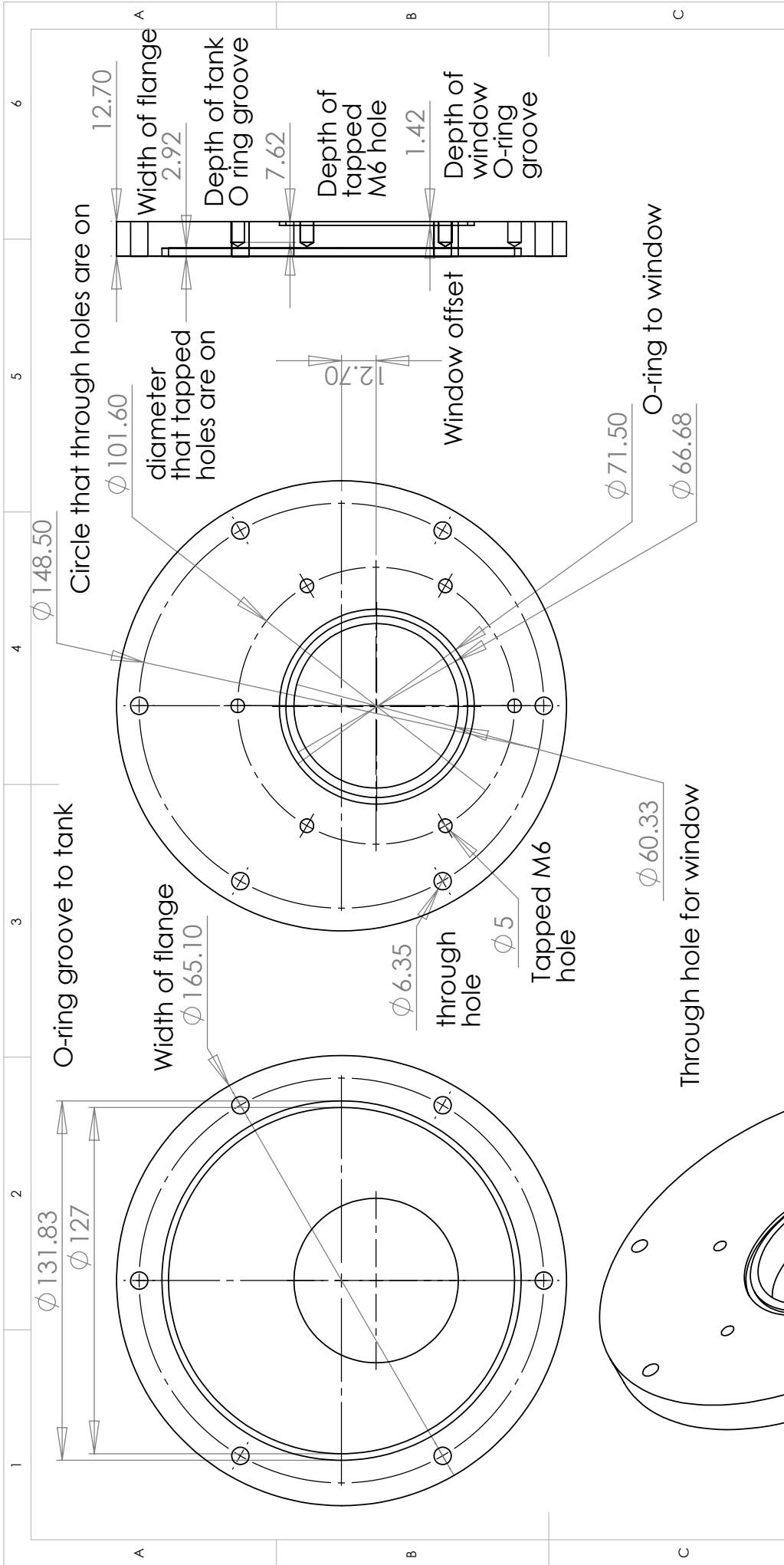

UNLESS OTHERWISE SPECIFIED: DIMENSIONS ARE IN MILLIMETERS		FINISH:		DEBUR AND BREAK SHARP EDGES		DO NOT SCALE DRAWING		REVISION	
SURFACE FINISH:		TOLERANCES:		NAME		SIGNATURE		DATE	
LINEAR:		ANGULAR:		DRAWN		CHK'D		APP'VD	
				MFG		Q.A		TITLE: Aluminium	
				MATERIAL: vacuum_window_inside_three_inch		WGT NO.		SCALE:1:2	
				WEIGHT:		SHEET 1 OF 1			

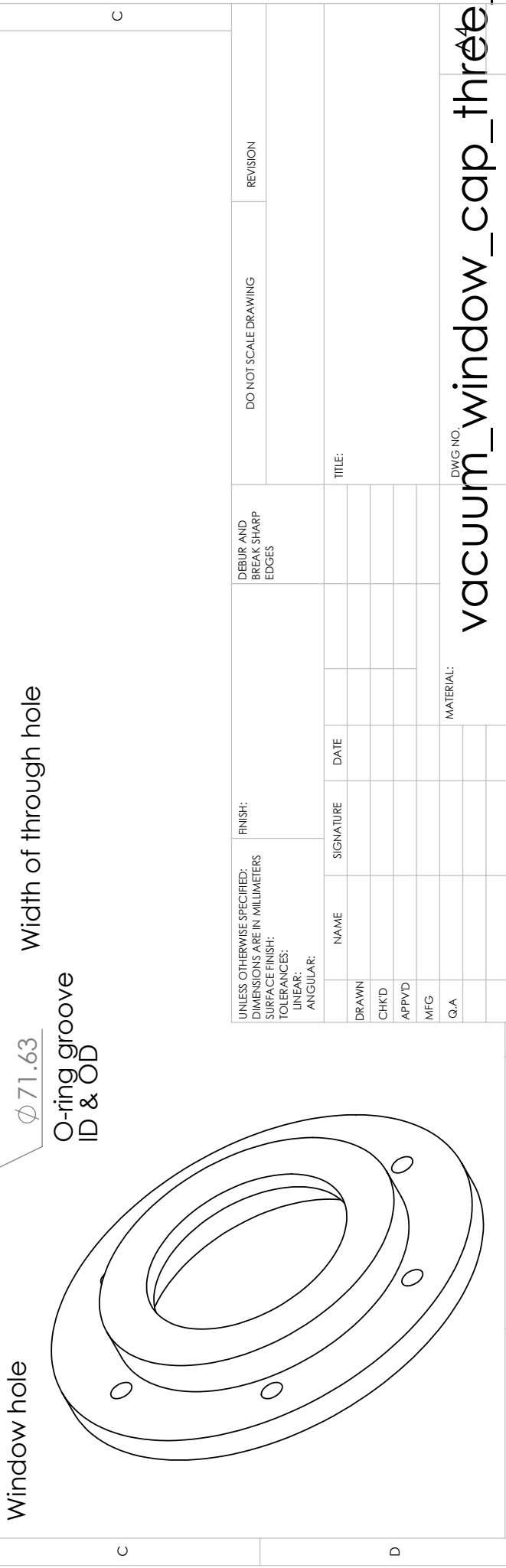
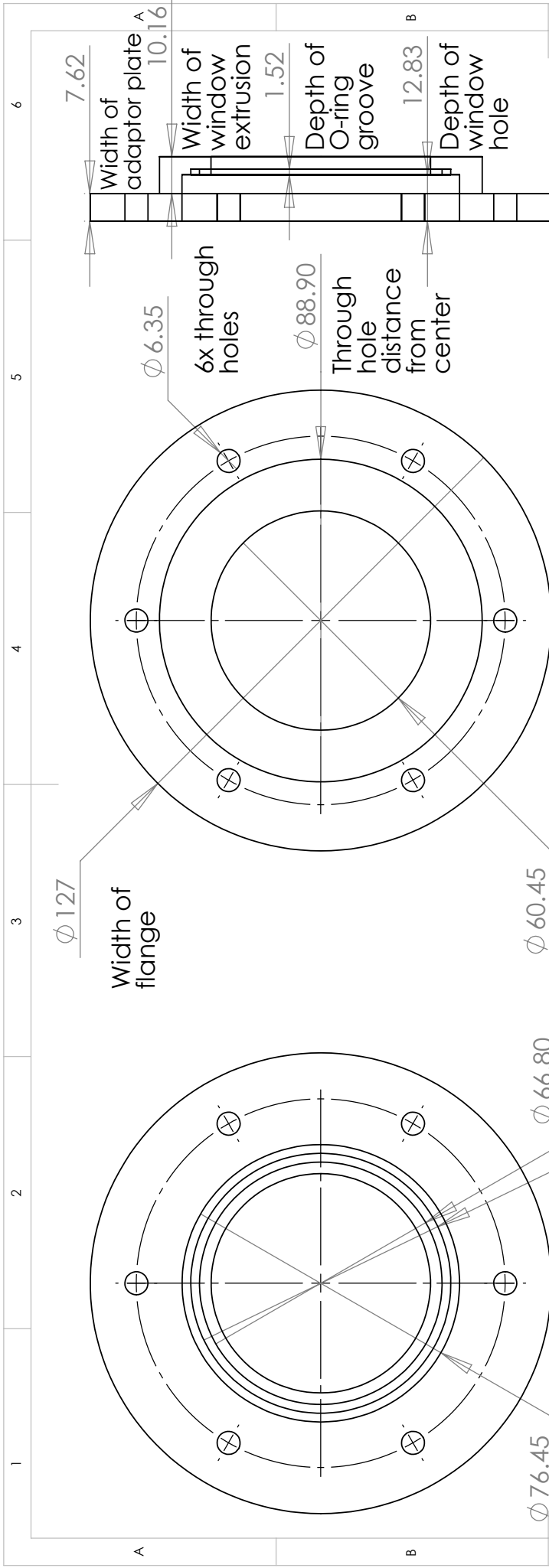

UNLESS OTHERWISE SPECIFIED: DIMENSIONS ARE IN MILLIMETERS		FINISH:		DEBUR AND BREAK SHARP EDGES		DO NOT SCALE DRAWING		REVISION	
SURFACE FINISH:		TOLERANCES:		NAME		SIGNATURE		DATE	
LINEAR:		ANGULAR:		DRAWN		CHK'D		APP'VD	
				MFG		Q.A		MATERIAL:	
				TITLE:				DWG NO.:	
								vacuum_window_cap_three	
								SCALE:1:2	
								WEIGHT:	
								SHEET 1 OF 1	

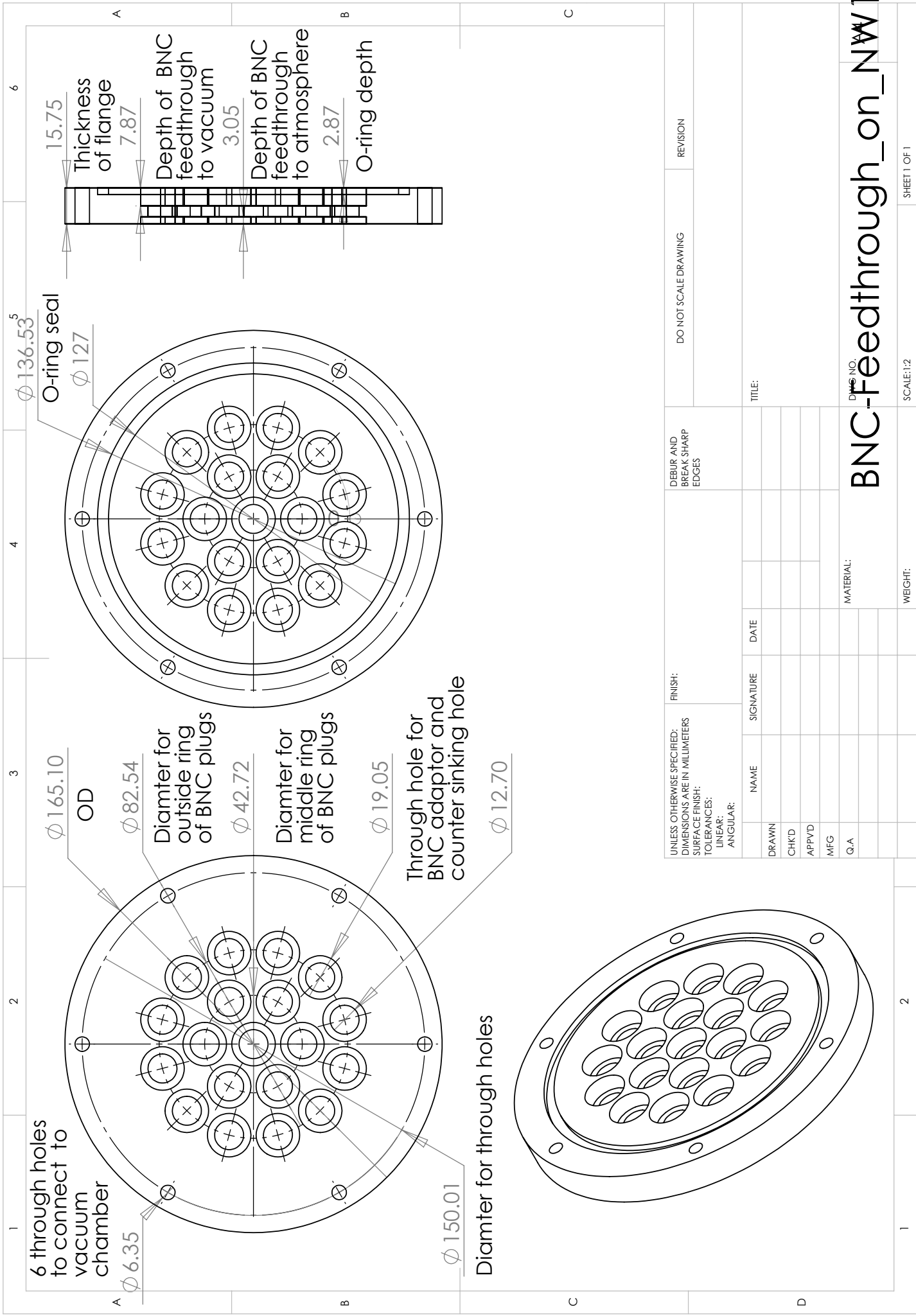

UNLESS OTHERWISE SPECIFIED: DIMENSIONS ARE IN MILLIMETERS		FINISH: DEBUR AND BREAK SHARP EDGES		DO NOT SCALE DRAWING		REVISION	
SURFACE FINISH:		TOLERANCES:		TITLE:			
LINEAR:		ANGULAR:		DRAWN			
NAME		SIGNATURE		DATE			
CHK'D							
APP'VD							
MFG							
Q.A							
MATERIAL:				DIMS NO.			
BNC-Feedthrough_on_NW15				SCALE:1:2			
WEIGHT:				SHEET 1 OF 1			

## References

- [1] Keisuke Goda. *Development of Techniques for Quantum Enhanced Laser-Interferometric Gravitation-Wave Detectors*. PhD thesis, Massachusetts Institute of Technology, August 2007.
- [2] Kirk McKenzie. *Experimental Demonstration of a Gravitational Wave Detector Configuration Below the Shot Noise Limit*. PhD thesis, Australian National University, June 2002.
- [3] Karsten Danzmann Simon Chelkowski, Henning Vahlbruch and Roman Schnabel. Coherent control of broadband vacuum squeezing. *Physical Review A*.
- [4] J. Taylor, R. Hulse, L. Fowler, G. Gullahorn, and J. Rankin. Further observations of the binary pulsar psr 1913+16. *Astrophysical Journal*, 206, 1976.